

let's talk   
science  
partnership program

**Pulleys & Gears**

# Agenda

let's talk   
science

- Introduction
- What's a Pulley?
- Playing with Pulleys
- What's a Gear?
- Playing with Gears
- Acting Game
- Conclusion



# Introduction

let's talk   
science

- What do scientists do?
- Where are they?
- What types of scientists are we?
- How does this type of science affect you?

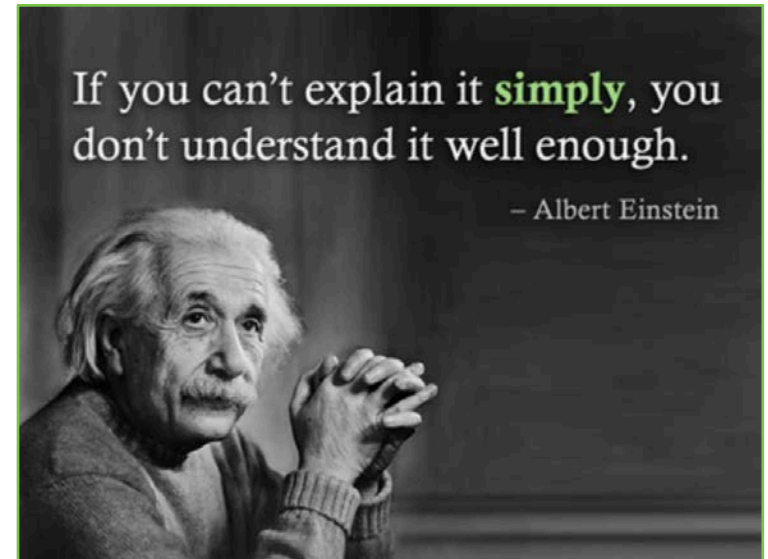

## What's a Pulley?

- Have you seen one before?
- How do they work?
- Where do you find them?
- Do you think they are helpful?

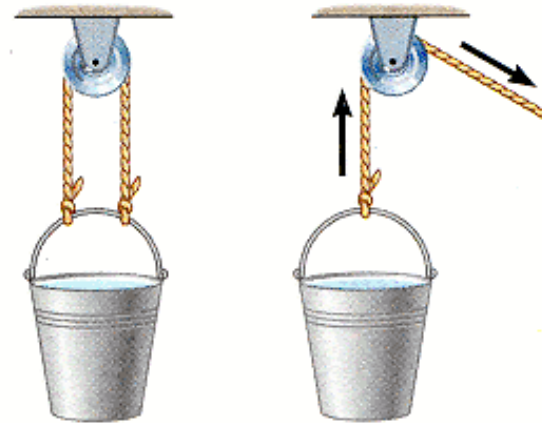

# Playing with Pulleys

- Single big pulley system
  - Start with only one pulley.
- Double pulley system
  - What's the difference between having two pulleys and having one?
- What if we added even more?

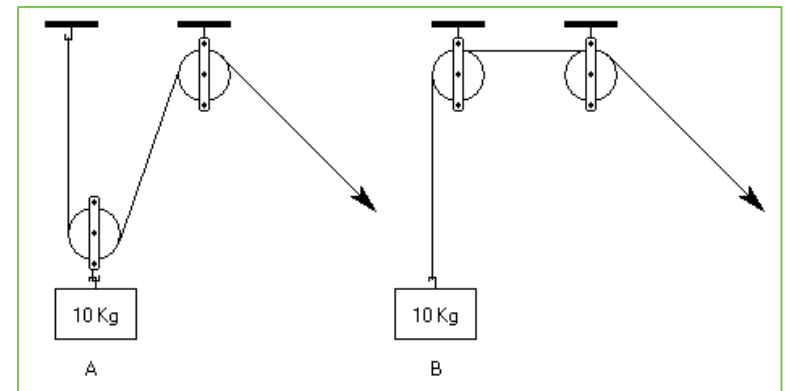
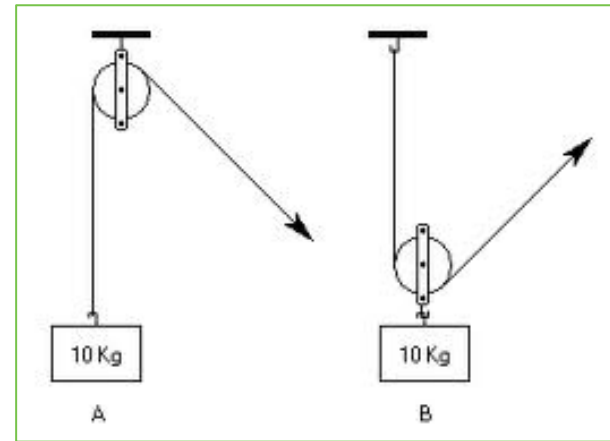

## What's a Gear?

- Have you seen one before?
- What is a gear?
- How do gears work?
- Where would you find one?
- What is the difference between pushing and pulling?

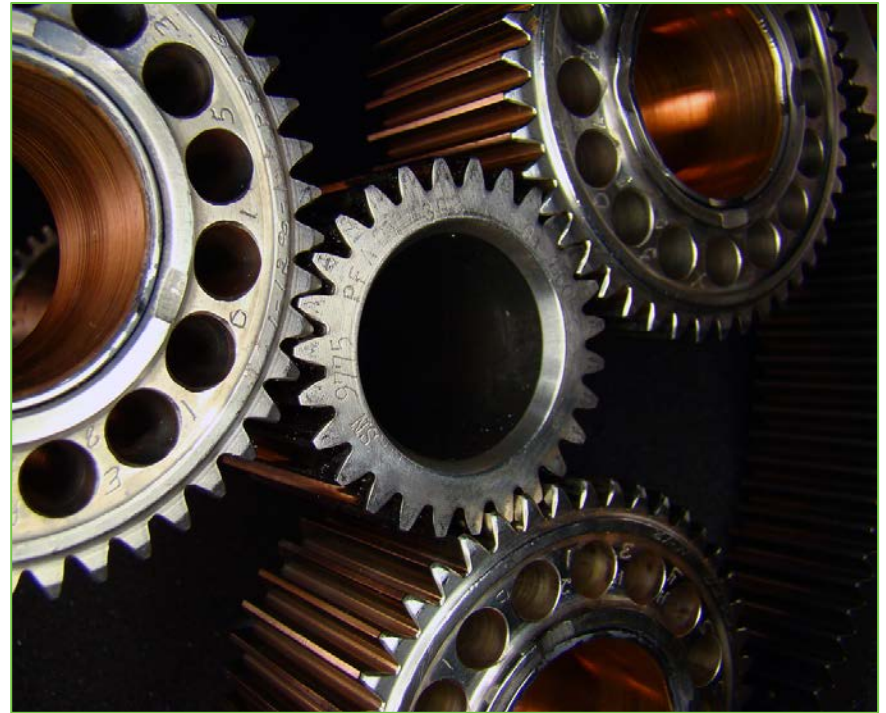

## Playing with Gears

- Do you think a gear can be useful by itself?
- Do the size of the gear's teeth matter?
- Should the teeth match up?
- Does the direction a gear turns matter?

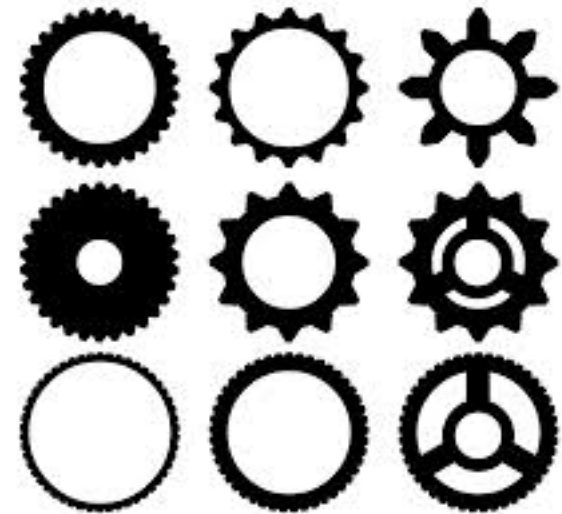

## Rotation Activity

- You will be given a number (1, 2 or 3).
- You will be asked to go to:
  - 1. The big pulley station.
  - 2. The small pulley station.
  - 3. The gear station.





## Acting Game

- Come up with actions for each of these words:
  - Pulley
  - Gear
  - Energy
  - Work
  - Crane
  - Clock
  - Strength
  - Motion
- Are there any more you can think of?

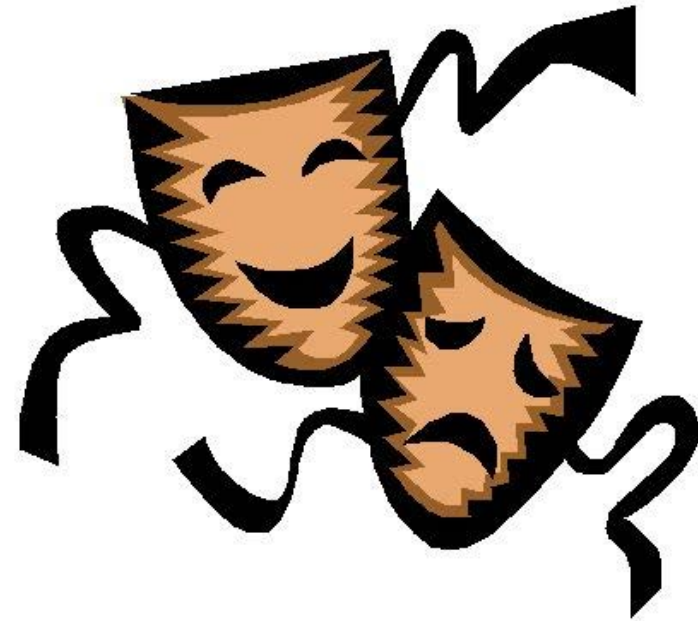

## Conclusion - Pulleys

- What is a pulley?
- Where would you find one?
- How are the two systems different?
- Where is the force being applied?
- Is it a push or pull?
- Does it take the same force to raise both of them?



## Conclusion - Gears

- How do gears work?
- Where would you find them?
- What directions do we see the gears turning?
- How does the number of gears affect the direction of rotation?
- How does the size of the gears affect the number of rotations?
- Where is energy spent
- Where is work done?
- How can this be used in real life?



## Debate!

- The bike... is the chain system an example of a pulley or of a gear?

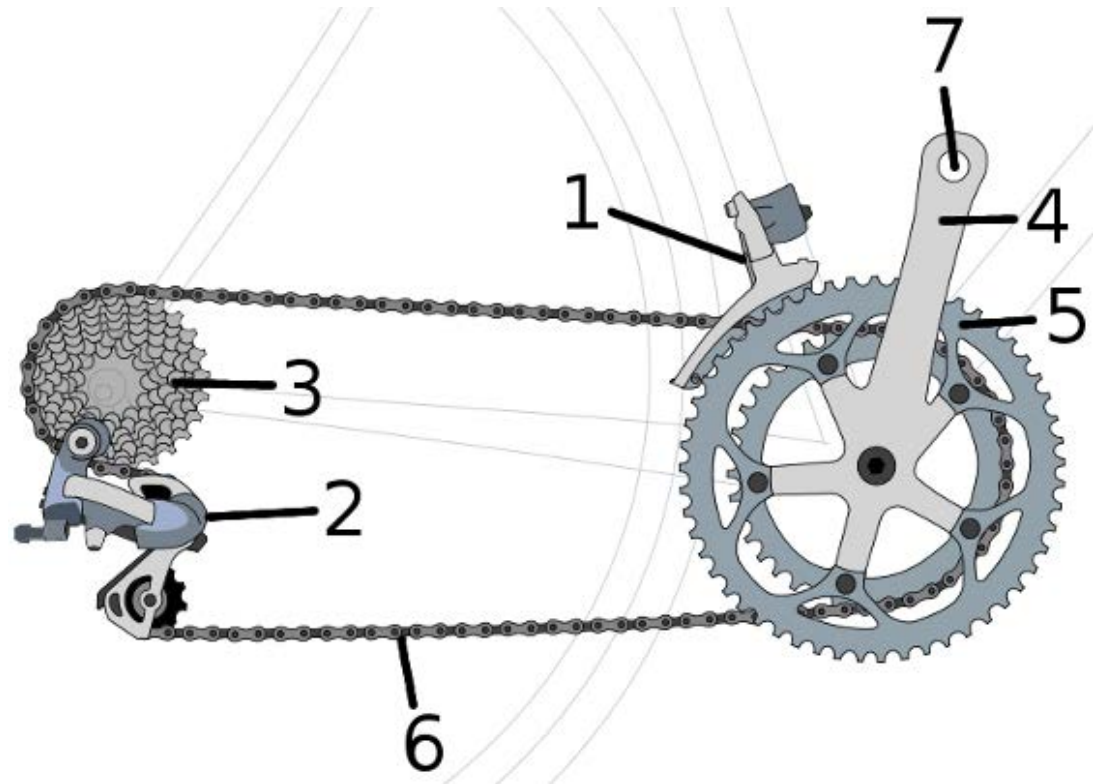

# Relevant Fields

- Machinery
- Construction
- Transportation
- Shipwork
- Well-drilling
- Manufacturing  
(Conveyor Belts)
- Recreation

let's talk   
science



let's talk   
science  
partnership program

**Thanks for having us!**